

TB6552FN/FNG, TB6552FL/FLG

DUAL-BRIDGE DRIVER IC FOR DC MOTORS

The TB6552FN/FNG/FL/FLG is a dual-bridge driver IC for DC motors with output transistors in an LD MOS structure with low ON-resistance. Two input signals, IN1 and IN2, can choose one of four modes such as CW, CCW, short brake, and stop mode. A PWM drive system supports high heat efficiency driving.

Features

- Power supply voltage for motor: $V_M \leq 15 \text{ V}$ (max)
- Power supply voltage for control: $V_{CC} = 2.7 \text{ V}$ to 6.0 V
- Output current: 1 A (max)
- Low ON resistor: 1.5Ω (typ.)
(Upper side + lower side combined @ $V_M = 5 \text{ V}$)
- Direct PWM control
- Standby system (power saving)
- CW/CCW/short brake/stop function modes
- Built-in thermal shutdown circuit
- Package: SSOP16 for TB6552FN/FNG /QON24 for TB6552FL/FLG

TB6552FN/FNG

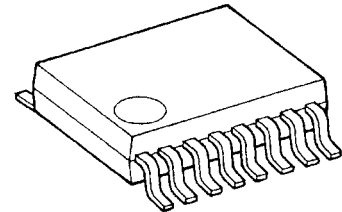

SSOP16-P-225-0.65B

TB6552FL/FLG

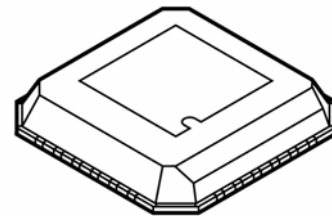

QON24-P-0505-0.50

TB6552FNG/FLG:

The following conditions apply to solderability:

*Solderability

1. Use of Sn-37Pb solder bath
 - *solder bath temperature = 230°C
 - *dipping time = 5 seconds
 - *number of times = once
 - *use of R-type flux
2. Use of Sn-3.0Ag-0.5Cu solder bath
 - *solder bath temperature = 245°C
 - *dipping time = 5 seconds
 - *number of times = once
 - *use of R-type flux

Weight

SSOP16-P-225-0.65B : 0.07 g (typ.)
QON24-P-0505-0.50 : 0.05 g (typ.)

* This product has a MOS structure and is sensitive to electrostatic discharge. When handling this product, ensure that the environment is protected against electrostatic discharge by using an earth strap, a conductive mat and an ionizer. Ensure also that the ambient temperature and relative humidity are maintained at reasonable levels.

Block Diagram

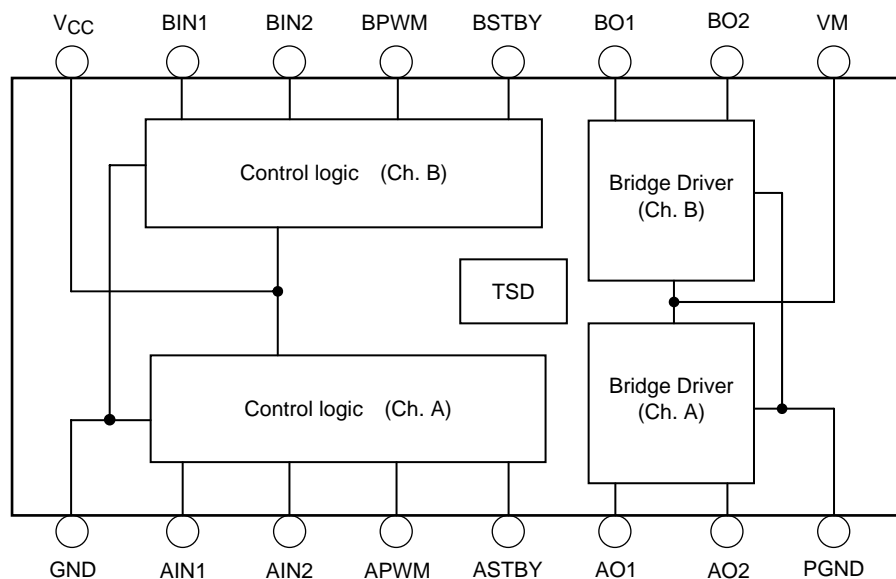

Pin Functions

Pin.Name	Pin No		Functional Description	Remarks
	FN/FNG	FL/FLG		
GND	1	21	Small-signal GND pin	GND for small-signal power supply (V _{CC})
AIN1	2	18	Control signal input 1 (Ch. A)	
AIN2	3	17	Control signal input 2 (Ch. A)	
APWM	4	16	PWM control signal input pin (Ch. A)	Input PWM signal
ASTBY	5	15	Standby control input pin (Ch. A)	Ch. A circuit is in standby (power save) state while this signal is Low.
AO1	7	13	Output pin 1 (Ch. A)	Ch. A connect to motor coil pin
AO2	8	11	Output pin 2 (Ch. A)	Ch. A connect to motor coil pin
PGND	9	10	GND pin for motor	GND for motor power supply (VM)
VM	6	14	Motor power supply pin	VM (ope) = 2.5 V to 13.5 V
BO2	10	8	Output pin 2 (Ch. B)	Ch. B connect to motor coil pin
BO1	11	5	Output pin 1 (Ch. B)	Ch. B connect to motor coil pin
BSTBY	12	4	Standby control input pin (Ch. B)	Ch. B circuit is in standby (power save) state while this signal is Low.
BPWM	13	3	PWM control signal input pin (Ch. B)	Input PWM signal
BIN2	14	2	Control signal input 2 (Ch. B)	
BIN1	15	1	Control signal input 1 (Ch. B)	
V _{CC}	16	22	Small-signal power supply pin	V _{CC} (ope) = 2.7 V to 5.5 V

Note: Pins 6, 7, 9, 12, 19, 20, 23 and 24 on the FL/FLG are NC (not connected) pins.

Input/Output Function (common for channel A and B)

Input				Output		
IN1	IN2	STBY	PWM	O1	O2	Mode
H	H	H	H	L	L	Short brake
			L			
L	H	H	H	L	H	CW/CCW
			L			L
H	L	H	H	H	L	CCW/CW
			L			L
L	L	H	H	OFF (high impedance)		Stop
			L			
H/L	H/L	L	H	OFF (high impedance)		Standby
			L			

Operating Description

- PWM control function**
 Speed can be controlled by inputting the high-level or low-level PWM signal to the pin PWM. When PWM control is provided, normal operation and short brake operation are repeated. To prevent penetrating current, dead time (t_2 and t_4) is provided in the IC.

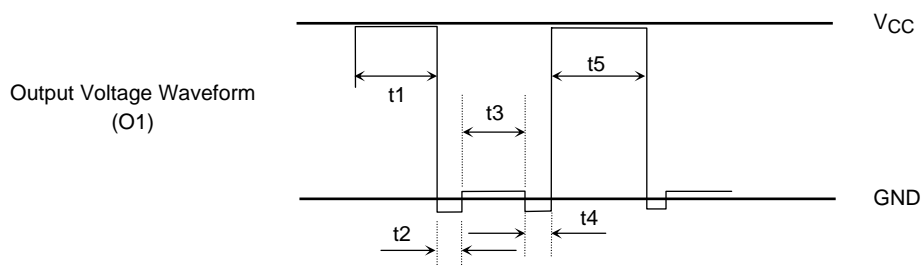
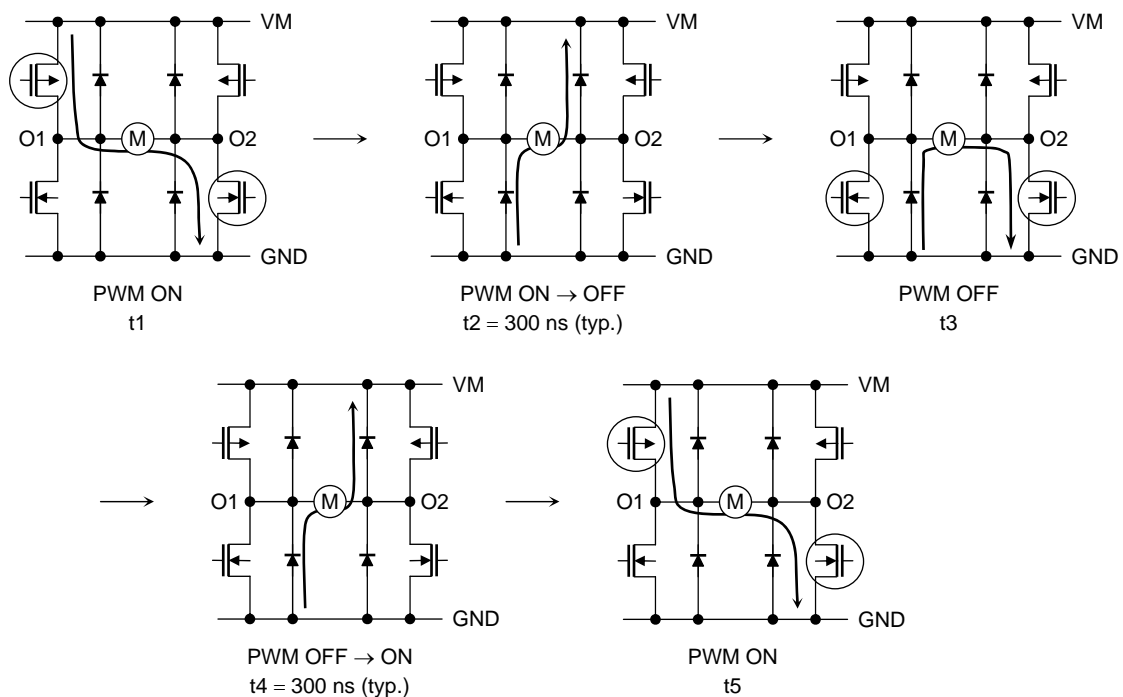

Note: Be sure to set the PWM pin to high if the PWM control function is not used.

- Switching characteristics of output transistors

The switching characteristics between the PWM input and the output transistors are shown below.

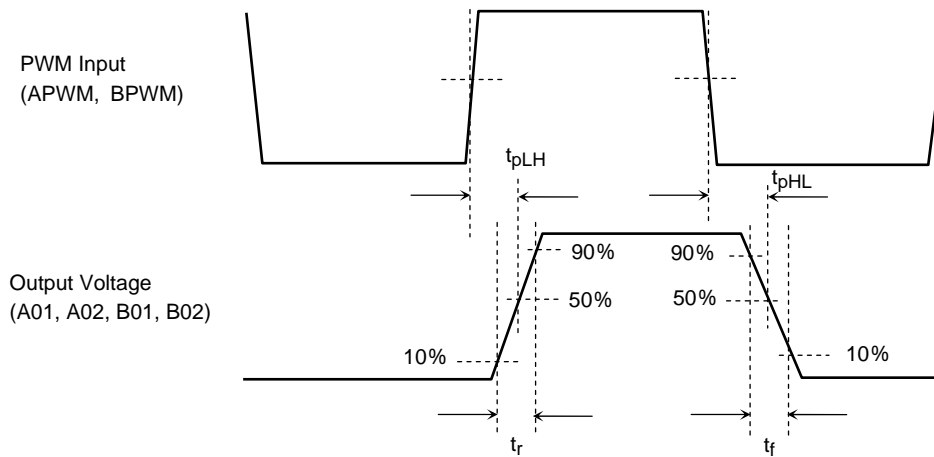

<Typical Value>

Item	Typical Value	Unit
t_{pLH}	1000	ns
t_{pHL}	1000	
t_r	100	
t_f	100	

- Input pins

Input pins AIN1, AIN2, APWM, ASTBY, BIN1, BIN2, BPWM and BSTBY have internal pull-down resistors that are connected to ground.

Absolute Maximum Ratings (Ta = 25°C)

Characteristics	Symbol	Rating	Unit	Remarks
Supply voltage	VM	15	V	
	VCC	6		
Input voltage	VIN	-0.2 to 6	V	IN1, 2, STBY and PWM pins
Output current	IOUT	1	A	
Power dissipation	PD	0.78 (Note 1)	W	
Operating temperature	Topr	-20 to 85	°C	
Storage temperature	Tstg	-55 to 150	°C	

Note 1: This rating is obtained when the product is mounted on a 50 × 30 × 1.6 mm glass-epoxy PCB of which 40% or more is occupied by copper.

Operating Range (Ta = -20 to 85°C)

Characteristics	Symbol	Min	Typ.	Max	Unit
Supply voltage (VCC)	VCC	2.7	3.0	5.5	V
Supply voltage (VM)	VM	2.5	5.0	13.5	V
Output current	Iout	—	—	0.8	A
PWM frequency	fPWM	—	—	100	kHz

Electrical Characteristics (unless otherwise specified, $V_{CC} = 3\text{ V}$, $V_M = 12\text{ V}$, $T_a = 25^\circ\text{C}$)

Characteristics		Symbol	Test Circuit	Test Condition	Min	Typ.	Max	Unit	
Supply current		$I_{CC}(\text{STP})$	—	Stop mode	—	0.9	1.2	mA	
		$I_{CC}(\text{W})$	—	CW/CCW mode	—	0.9	1.2		
		$I_{CC}(\text{SB})$	—	Short break mode	—	0.9	1.2		
		$I_{CC}(\text{STB})$	—	(Standby mode)	—	—	10	μA	
		$I_M(\text{STB})$	—		—	—	1		
Control circuit		Input voltage	V_{INH}	—	2	—	$V_{CC} + 0.2$	V	
			V_{INL}	—	-0.2	—	0.8		
		Hysteresis voltage	$V_{\text{IN}}(\text{HIS})$	—	(Not tested)	—	0.2	—	μA
		Input current	I_{INH}	—		5	15	25	
I_{INL}	—			—	—	1			
Standby circuit		Input voltage	V_{INSH}	—	2	—	$V_{CC} + 0.2$	V	
			V_{INSL}	—	-0.2	—	0.8		
		Input current	I_{INSH}	—		5	10	20	μA
			I_{INSL}	—		—	—	1	
Output saturating voltage		$V_{\text{sat}}(\text{U} + \text{L})$		$I_o = 0.2\text{ A}$	—	0.3	0.4	V	
	$I_o = 0.8\text{ A}$		—	1.2	1.5				
Output leakage current		$I_L(\text{U})$		$V_M = 15\text{ V}$	—	—	1	μA	
		$I_L(\text{L})$			—	—	1		
Diode forward voltage		$V_F(\text{U})$		$I_o = 0.8\text{ A}$	—	1	1.2	V	
		$V_F(\text{L})$		$I_o = 0.8\text{ A}$	—	1	1.2		
PWM control circuit		PWM frequency	f_{PWM}		—	—	100	kHz	
		Minimum clock pulse width	$t_w(\text{PWM})$		—	—	10	μs	
Output transistor switching		T_r		Not tested	—	100	—	ns	
		T_f			—	100	—		
		$t_{\text{pLH}}(\text{PWM})$			—	1000	—		
		$t_{\text{pHL}}(\text{PWM})$			—	1000	—		
Thermal shutdown circuit operating temperature		T_{SD}		(Not tested)	—	170	—	$^\circ\text{C}$	
Thermal shutdown hysteresis		ΔT_{SD}		(Not tested)	—	20	—	$^\circ\text{C}$	

Characteristic Wave Form

TB6552FN/FNG

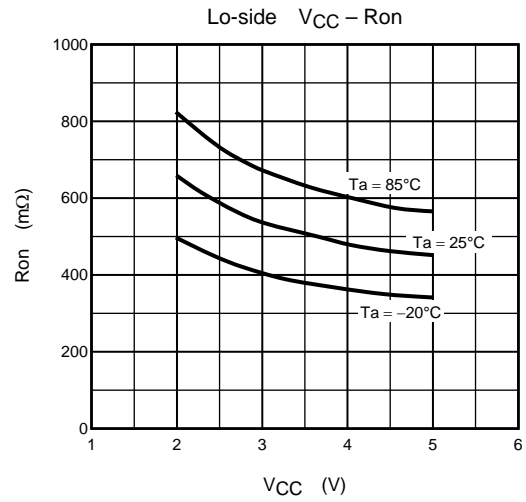
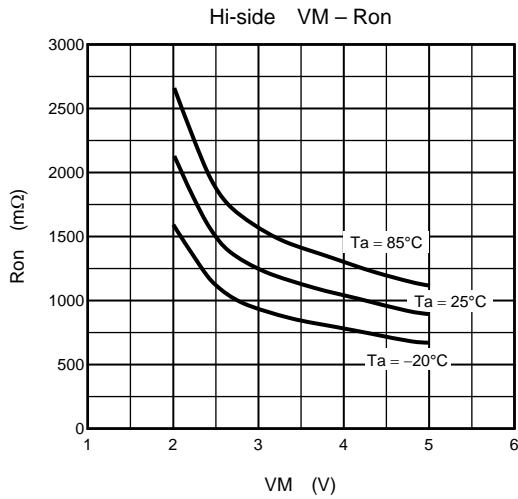
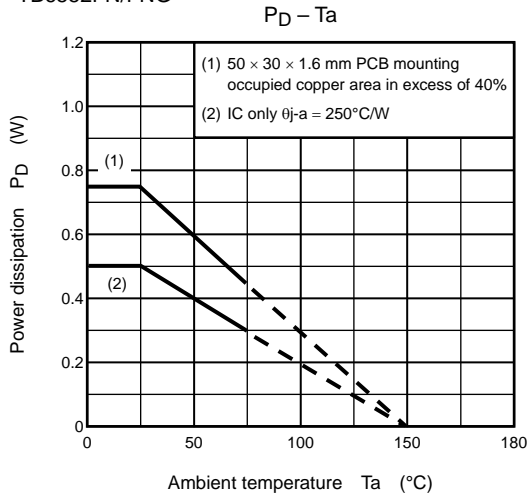

Typical Application Diagram

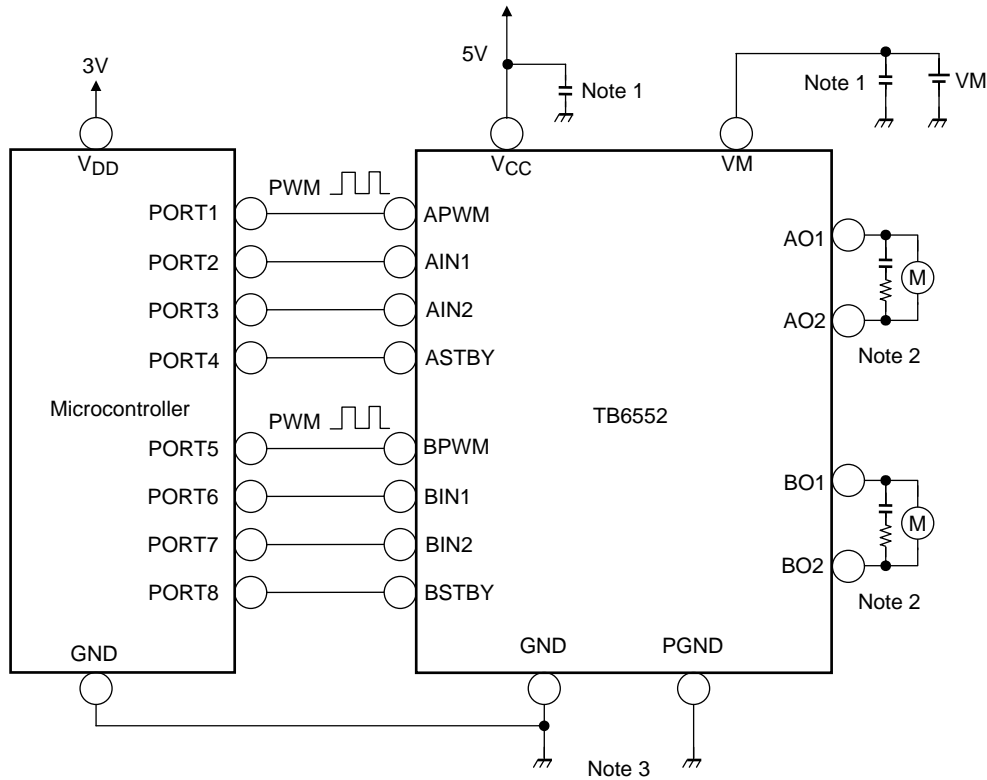

Note 1: The power supply capacitor should be connected as close as possible to the IC.

Note 2: When connecting the motor pins through the capacitor for reducing noise, connect a resistor to the capacitor to limit the charge current.

Note 3: Avoid using common impedance for GND and PGND.

Note 4: Utmost care is necessary in the design of the output, V_{CC} , V_M , and GND lines since the IC may be destroyed by short-circuiting between outputs, air contamination faults, or faults due to improper grounding, or by short-circuiting between contiguous pins.

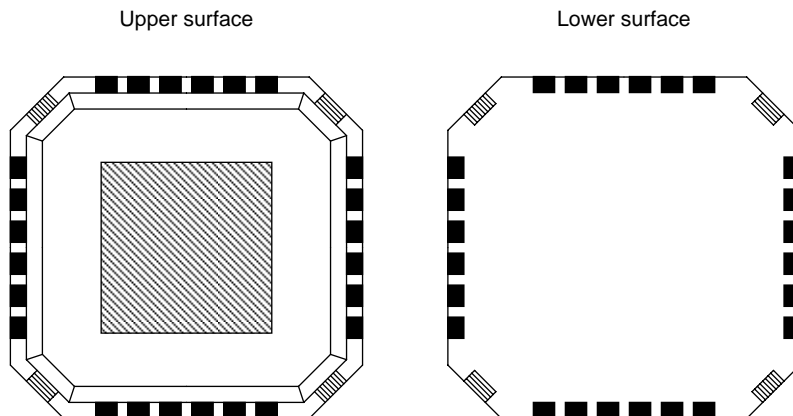
Requests Concerning Use of QON**Outline Drawing of Package**

When using QON, take into account the following items.

Caution

- (1) Do not carry out soldering on the island sections in the four corners of the package (indicated by the hatched sections in the figure for the lower surface, above left) with the aim of increasing mechanical strength.
- (2) The projecting island sections on the package surfaces (indicated by the hatched sections in the figures for the upper and lower surfaces above) must be electrically insulated from outside when used.

Note 6: Ensure that the island sections (indicated by the hatched sections in the figure for the lower surface, above left) do not come into contact with solder from through-holes on the board layout.

- When mounting or soldering, take care to ensure that neither static electricity nor electrical overstress is applied to the IC. (Measures to prevent electrostatic discharge, leaks, etc.)
- When incorporating the IC into a set, adopt a set design that does not apply voltage directly to the island section.

Package Dimensions

SSOP16-P-225-0.65B

Unit : mm

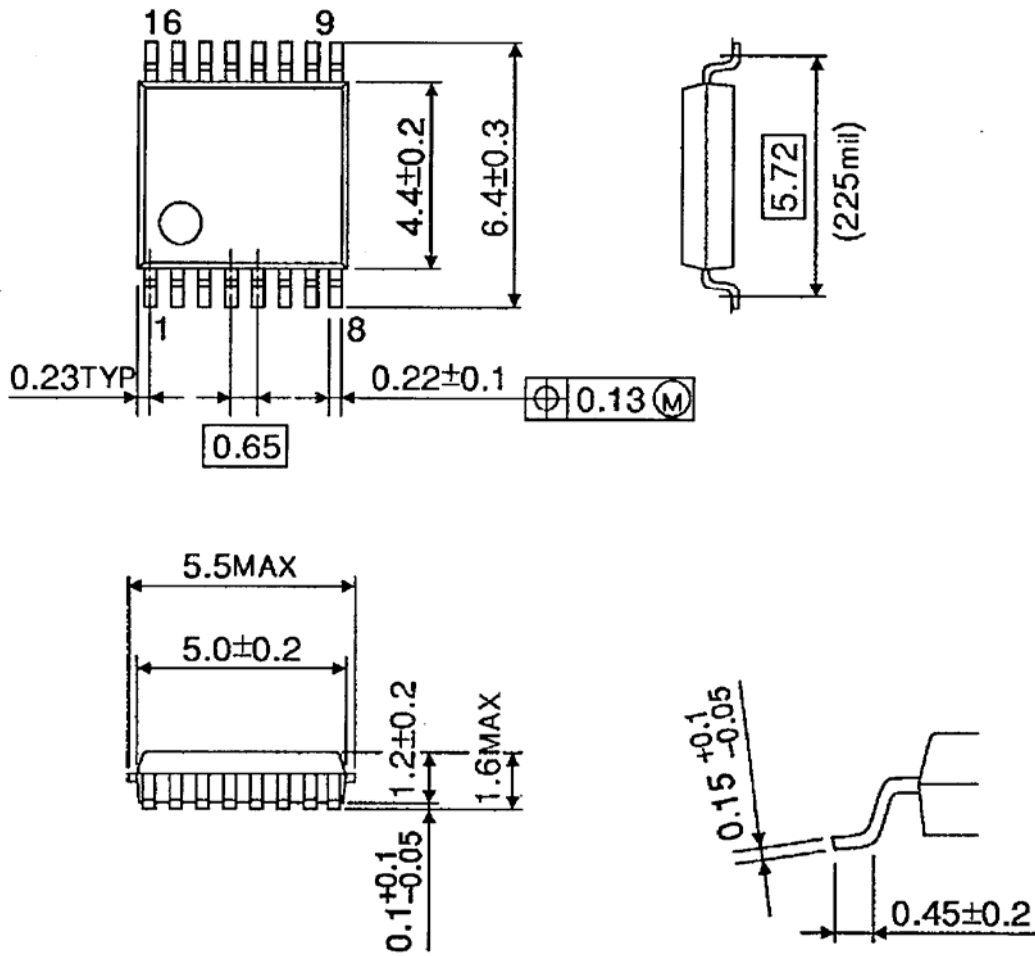

Weight: 0.07 g (typ.)

Package Dimensions

QON24-P-0505-0.50

Unit: mm

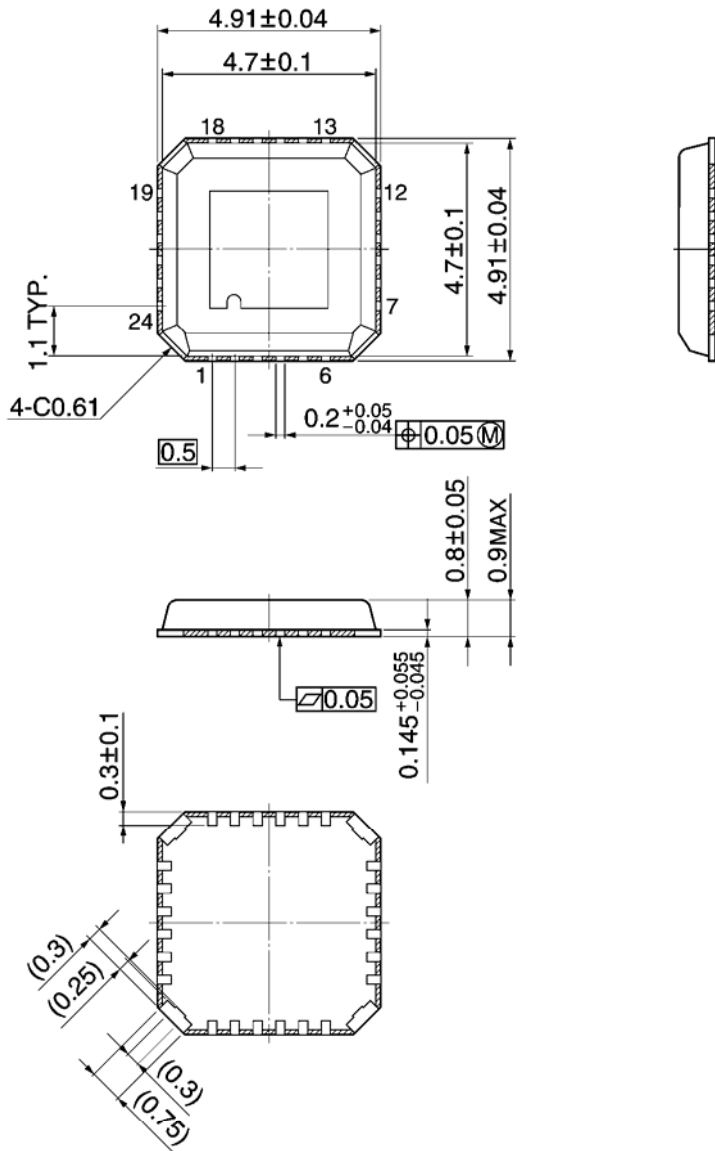

Note 1) The solder plating portion in four corners of the package shall not be treated as an external terminal.

Note 2) Do not carry out soldering at the four corners of the package.

Note 3)  area : Resin surface

Weight: 0.05 g (typ.)

Notes on Contents

1. Block Diagrams

Some of the functional blocks, circuits, or constants in the block diagram may be omitted or simplified for explanatory purposes.

2. Equivalent Circuits

The equivalent circuit diagrams may be simplified or some parts of them may be omitted for explanatory purposes.

3. Timing Charts

Timing charts may be simplified for explanatory purposes.

4. Application Circuits

The application circuits shown in this document are provided for reference purposes only. Thorough evaluation is required, especially at the mass production design stage.

Toshiba does not grant any license to any industrial property rights by providing these examples of application circuits.

5. Test Circuits

Components in the test circuits are used only to obtain and confirm the device characteristics. These components and circuits are not guaranteed to prevent malfunction or failure from occurring in the application equipment.

IC Usage Considerations

Notes on handling of ICs

- [1] The absolute maximum ratings of a semiconductor device are a set of ratings that must not be exceeded, even for a moment. Do not exceed any of these ratings.
Exceeding the rating(s) may cause the device breakdown, damage or deterioration, and may result injury by explosion or combustion.
- [2] Use an appropriate power supply fuse to ensure that a large current does not continuously flow in case of over current and/or IC failure. The IC will fully break down when used under conditions that exceed its absolute maximum ratings, when the wiring is routed improperly or when an abnormal pulse noise occurs from the wiring or load, causing a large current to continuously flow and the breakdown can lead smoke or ignition. To minimize the effects of the flow of a large current in case of breakdown, appropriate settings, such as fuse capacity, fusing time and insertion circuit location, are required.
- [3] If your design includes an inductive load such as a motor coil, incorporate a protection circuit into the design to prevent device malfunction or breakdown caused by the current resulting from the inrush current at power ON or the negative current resulting from the back electromotive force at power OFF. IC breakdown may cause injury, smoke or ignition.
Use a stable power supply with ICs with built-in protection functions. If the power supply is unstable, the protection function may not operate, causing IC breakdown. IC breakdown may cause injury, smoke or ignition.
- [4] Do not insert devices in the wrong orientation or incorrectly.
Make sure that the positive and negative terminals of power supplies are connected properly. Otherwise, the current or power consumption may exceed the absolute maximum rating, and exceeding the rating(s) may cause the device breakdown, damage or deterioration, and may result injury by explosion or combustion.
In addition, do not use any device that is applied the current with inserting in the wrong orientation or incorrectly even just one time.

Points to remember on handling of ICs**(1) Thermal Shutdown Circuit**

Thermal shutdown circuits do not necessarily protect ICs under all circumstances. If the thermal shutdown circuits operate against the over temperature, clear the heat generation status immediately.

Depending on the method of use and usage conditions, such as exceeding absolute maximum ratings can cause the thermal shutdown circuit to not operate properly or IC breakdown before operation.

(2) Heat Radiation Design

In using an IC with large current flow such as power amp, regulator or driver, please design the device so that heat is appropriately radiated, not to exceed the specified junction temperature (T_J) at any time and condition. These ICs generate heat even during normal use. An inadequate IC heat radiation design can lead to decrease in IC life, deterioration of IC characteristics or IC breakdown. In addition, please design the device taking into consideration the effect of IC heat radiation with peripheral components.

(3) Back-EMF

When a motor rotates in the reverse direction, stops or slows down abruptly, a current flow back to the motor's power supply due to the effect of back-EMF. If the current sink capability of the power supply is small, the device's motor power supply and output pins might be exposed to conditions beyond maximum ratings. To avoid this problem, take the effect of back-EMF into consideration in system design.

RESTRICTIONS ON PRODUCT USE

070122EBA_R6

- The information contained herein is subject to change without notice. 021023_D
- TOSHIBA is continually working to improve the quality and reliability of its products. Nevertheless, semiconductor devices in general can malfunction or fail due to their inherent electrical sensitivity and vulnerability to physical stress. It is the responsibility of the buyer, when utilizing TOSHIBA products, to comply with the standards of safety in making a safe design for the entire system, and to avoid situations in which a malfunction or failure of such TOSHIBA products could cause loss of human life, bodily injury or damage to property.
In developing your designs, please ensure that TOSHIBA products are used within specified operating ranges as set forth in the most recent TOSHIBA products specifications. Also, please keep in mind the precautions and conditions set forth in the "Handling Guide for Semiconductor Devices," or "TOSHIBA Semiconductor Reliability Handbook" etc. 021023_A
- The TOSHIBA products listed in this document are intended for usage in general electronics applications (computer, personal equipment, office equipment, measuring equipment, industrial robotics, domestic appliances, etc.). These TOSHIBA products are neither intended nor warranted for usage in equipment that requires extraordinarily high quality and/or reliability or a malfunction or failure of which may cause loss of human life or bodily injury ("Unintended Usage"). Unintended Usage include atomic energy control instruments, airplane or spaceship instruments, transportation instruments, traffic signal instruments, combustion control instruments, medical instruments, all types of safety devices, etc. Unintended Usage of TOSHIBA products listed in this document shall be made at the customer's own risk. 021023_B
- The products described in this document shall not be used or embedded to any downstream products of which manufacture, use and/or sale are prohibited under any applicable laws and regulations. 060106_Q
- The information contained herein is presented only as a guide for the applications of our products. No responsibility is assumed by TOSHIBA for any infringements of patents or other rights of the third parties which may result from its use. No license is granted by implication or otherwise under any patents or other rights of TOSHIBA or the third parties. 070122_C
- Please use this product in compliance with all applicable laws and regulations that regulate the inclusion or use of controlled substances.
Toshiba assumes no liability for damage or losses occurring as a result of noncompliance with applicable laws and regulations. 060819_AF
- The products described in this document are subject to foreign exchange and foreign trade control laws. 060925_E